

# INKOMA /ALBERT

Great ideas need drive.

## INKOTURN COUPLINGS

The INKOMA Inkoturn coupling (IKT) is a flexible coupling with high torsional rigidity, which has been developed for applications requiring high speed and where shaft misalignment is present. It can accept axial, radial and angular misalignment. Due to the design of the coupling negligible reaction forces are seen at the bearings due to misalignment.

Developed with low mass, low inertia and being dynamically balanced the IKT coupling is suitable for dynamic applications where angular misalignment is present.

Under normal operating conditions the coupling is maintenance free and offers a long service life. However, the coupling should be protected against jet water, dust and dirt ingress. As it has a modular structure it can be installed complete or assembled in parts. The central disc (element) is manufactured with special material therefore it is electrically isolating and can absorb oscillation and impact loads. Torque can be transferred backlash free with maximum angular misalignment.



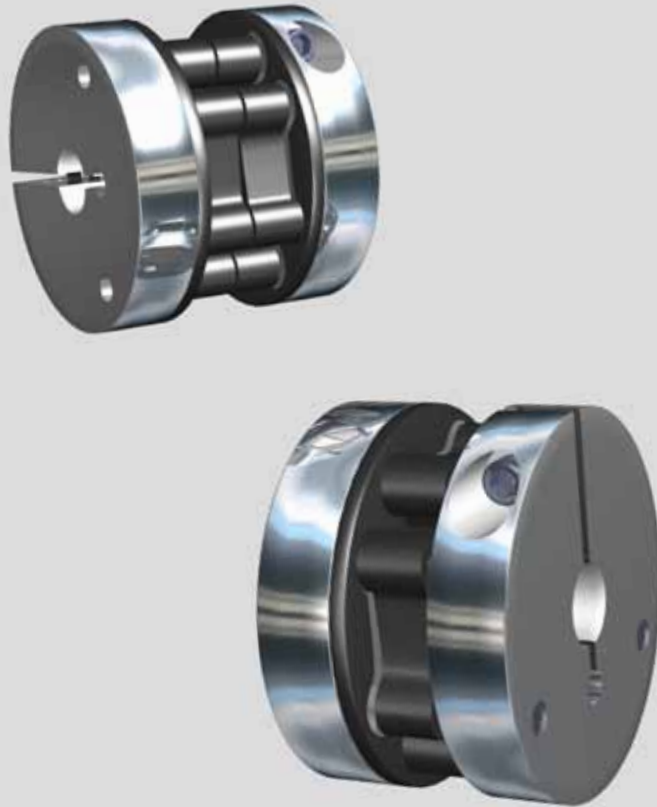

#### STRUCTURE AND FUNCTION

The coupling consists of two anodized aluminium clamping hubs, available with different bore sizes, each fitted with a clamping screw to lock the hub into position. The clamping hubs are fitted with steel drive pins and are connected via a special plastic element.

The use of special material and geometry of the central disc result in minimal reaction forces being seen under misalignment conditions. Reaction forces are virtually zero with low misalignment.

The Inkoturn coupling is available in "single" and "double" disc design. The double disc design consists of two central discs and can transmit higher torque than the single disc version.

Special designs and sizes are available. Customised designs for applications requiring special materials, as required by the Food Industry for example can be achieved.

Typical applications are: rotary transducers, encoders, tachos, measuring systems, packaging machines, paper industry, printers, etc.

Contact our sales offices for further details.

#### INKOTURN TEST STAND

All technical data for the coupling was obtained by our own test equipment developed in conjunction with technical universities. The values calculated by the Finite Element Analysis (FEA) were confirmed by our own tests and by applications in the field.

# TECHNICAL INFORMATION

MODEL	RADIAL MISALIGNM. $\pm R$ . [MM]	ANGULAR MISALIGNM. $\alpha$ [°]	STATIC TORQUE $T_{STAT}$ . [NM]	MAX. TORQUE $T_{MAX}$ . [NM]	MAX. SPEED $n_{MAX}$ . [1/MIN]
<b>SINGLE DESIGN</b>					
IKT-21.25	1	1,5	0,8	1,2	10000
IKT-26.25	1	1,5	0,8	1,2	10000
IKT-24.37	1	1,5	2,2	3,3	10000
IKT-30.37	1	1,5	2,2	3,3	10000
IKT-38.58	1,5	1,5	7,5	10,5	10000
IKT-45.58	1,5	1,5	7,5	10,5	10000
IKT-60.75	2	1,5	16	24	10000
<b>DOUBLE DESIGN</b>					
IKT-27.25	1	1,5	1,6	2,4	10000
IKT-32.25	1	1,5	1,6	2,4	10000
IKT-34.37	1	1,5	4,4	6,6	10000
IKT-40.37	1	1,5	4,4	6,6	10000
IKT-53.58	1,5	1,5	15	21	10000
IKT-59.58	1,5	1,5	15	21	10000
IKT-80.75	2	1,5	32	48	10000

Request our complete catalogue or visit us on the Internet.  
You can obtain a free download of our brochure or the product drawing of the selected item using the CADENAS facility.

## EXAMPLES FOR POSSIBLE SPECIAL DESIGNS



Use of different hub diameters

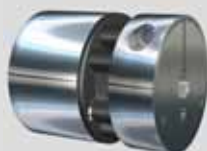

Use of long hubs



Direct connection of the central disc to customers machine or shaft



Enlargement of axial length



Connection of adaptors

# INKOMA /ALBERT

Great ideas need drive.

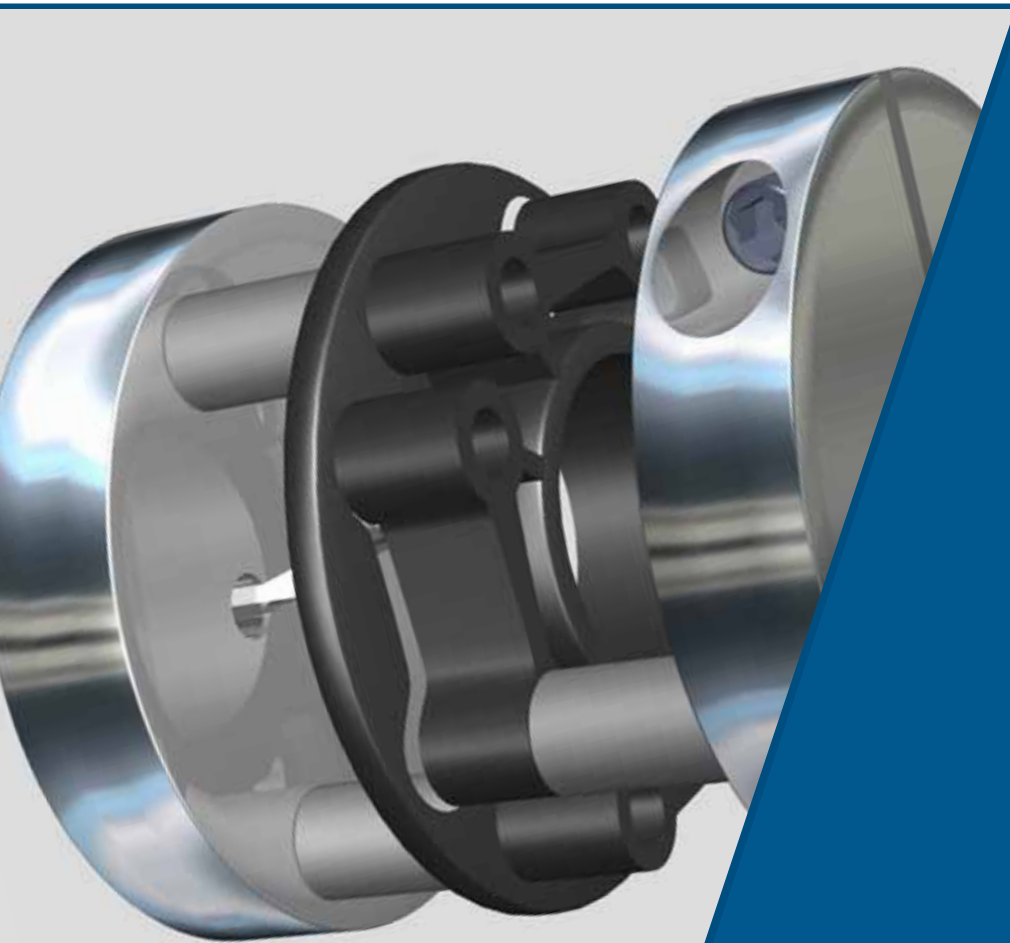

© Maschinenfabrik INKOMA 2014  
Photography, layout, concept: [www.fbwk.at](http://www.fbwk.at)

INKOMA Maschinenbau GmbH  
Lange Göhren 14  
D- 39171 Osterweddingen  
T: +49 (0) 39205 453-0  
F: +49 (0) 39205 453-433  
[info@inkoma.de](mailto:info@inkoma.de)  
[www.inkoma.de](http://www.inkoma.de)